

TECHNICAL MANUAL

DIRECT SUPPORT AND GENERAL SUPPORT MAINTENANCE MANUAL

TEST SET, RADIO TS-1588/AIC

(NSN 6625-00-895-6646)

AND

TEST SET, RADIO TS -1588A/AIC

(NSN6625-00-239-6010)

HEADQUARTERS, DEPARTMENT OF THE ARMY

JANUARY 1975

Direct Support and General Support Maintenance Manual

TEST SET, RADIO TS-1588/AIC (NSN 6625-00-895-6646)

AND TEST SET, RADIO TS-1588A/AIC

(NSN 6625-00-239-6010)

		Paragraph Page	
CHAPTER Section	1. INTRODUCTION		
	I. General		
	Scope	1-1	1-1
	Indexes of publications	1-2	1-1
	Reporting of errors	1-3	1-1
	II. Description and data		
	Description	1-4	1-1
	Tabulated data	1-5	1-1
	2. FUNCTIONING		
	Application, block diagram analysis	2-1	2-1
	Receiving test circuit functioning.	2-2	2-1
	Transmission test circuit functioning	2-3	2-3
	Self-test circuit functioning	2-4	2-6
	3. DIRECT SUPPORT MAINTENANCE		
	I. General		
	General instructions	3-1	3-1
	Organization of troubleshooting procedures	3-2	3-1
	Tools and test equipment required	3-3	3-1
	II. Troubleshooting		
	Voltage and resistance measurements	3-4	3-1
	Troubleshooting of interphone test set	3-5	3-2
	III. Maintenance of Test Set, Radio TS-1588(*)/AIC		
	General	3-6	3-8
	Repair of hinges and replacement of hinges, latches, and handles	3-7	3-8
	Removal and replacement of switches	3-8	3-9
	Removal and replacement of relay K1	3-9	3-9
	Removal and replacement of lampholders	3-10	3-9
	Removal and replacement of fuseholders	3-11	3-9
	Removal and replacement of terminal boards	3-12	3-10
	Direct support test procedures	3-13	3-10
	4. GENERAL SUPPORT MAINTENANCE AND TEST PROCEDURES		
	General	4-1	4-1
	Tools and test equipment required for general support	4-2	4-1
	Physical tests and inspections	4-3	4-1
	Resistance Check	4-4	4-3
	Electrical tests	4-5	4-5
APPENDIX	REFERENCES		A-1

*This manual supersedes TM 11-6625-441-35, 19 October 1961, including all changes.

LIST OF ILLUSTRATIONS

Figure No.	Title	Page
2-1.	Interphone test set application, block diagram	2-1
2-2.	Interphone test set, receiving test set circuit, simplified schematic diagram	2-3
2-3.	Interphone test set, transmission test circuits, simplified schematic diagram	2-5
3-1.	Test Set, Radio TS-1588/AIC, upper front panel, parts location .	3-4
3-2.	Test Set, Radio TS-1588/AIC, lower front panel, parts location	3-5
3-3.	Test Set, Radio TS-1588A/AIC, upper front panel, parts location .	3-7
3-4.	Test Set, Radio TS-1588A/AIC, lower front panel, parts location	3-8
4-1.	Test Set, Radio TS-1588(*)/AIC resistance check connection diagram	4-5
4-2.	Test Set, Radio TS-1588(*)/AIC electrical test connection diagram . .	4-7
FO-1.	Color code marking for MIL-STD resistors, inductors, and capacitors	In back of manual
FO-2.	Test Set, Radio TS-1588(*)/AIC, self-test circuits simplified schematic diagram	In back of manual
FO-3.	Test Set, Radio TS-1588(*)/AIC schematic diagram .	In back of manual
FO-4.	Test Set, Radio TS-1588(*)/AIC wiring diagram	In back of manual

CHAPTER 1

INTRODUCTION

Section I. GENERAL

1-1. Scope

a. This manual describes and covers direct support and general support maintenance for Test Sets, Radio TS-1588/AIC and TS-1588A/AIC (interphone test set). Included are instructions appropriate to direct support and general support maintenance for troubleshooting, testing, repairing equipment, replacing parts and repairing specific parts. In addition, this manual provides a listing of tools, materials, and test equipment used by direct support and general support maintenance.

b. Official nomenclature and government type designation, including the symbol (*) is used to identify all models of the equipment covered by this manual; therefore, Test Set, Radio TS-1588(*)/AIC represents Test Sets, Radio TS-1588/AIC and TS-1588A/AIC.

c. The two basic configurations of Test Set, Radio TS-1588(*) /AIC are identical, except for the addition of an EMER position on RECEIVER SEL switch S4 and an ALTN position on TRANSMITTER SEL switch S5 and accompanying circuitry installed on Test Set, Radio TS-1588A/AIC. The EMER position of RECEIVER SEL switch S4 and the ALTN position of TRANSMITTER SEL switch S5 provide test and checkout capability for the emergency receiver audio input circuitry and the alternate transmitter number 1 audio output circuitry, respectively, of Control, Intercommunication Set C-1611(*)/AIC.

d. The complete manual for Test Set, Radio

TS-1588(*)/AIC includes TM 11-6625-441-12, TM 11-6625-441-20P, and TM 11-6625-441-34P. To better understand the functions of Test Set, Radio TS-1588(*)/AIC and its relation to Control, Intercommunication Set C-1611(*)/AIC, TM 11-5831-201-35 should be consulted and understood.

e. Throughout this manual, Test Set, Radio TS-1588(*)/AIC will be referred to as interphone test set, and Control, Intercommunication Set C-1611(*)/AIC will be referred to as interphone control.

NOTE

For applicable forms and records, refer to TM 11-6625-441-12.

1-2. Indexes of Publications

a. *DA Pam 310-4.* Refer to the latest issue of DA Pam 310-4 to determine whether there are new editions, changes, or additional publications pertaining to the equipment.

b. *DA Pam 310-7.* Refer to DA Pam 310-7 to determine whether there are modification work orders (MWO'S) pertaining to the equipment.

1-3. Reporting of Errors

The reporting of errors, omissions, and recommendations for improving this publication by the individual user is encouraged. Reports should be submitted on DA Form 2028 (Recommended Changes to Publications and Blank Forms) and forwarded direct to Commander, US Army Electronics Command, ATTN: AMSEL-MA-AC, Fort Monmouth, New Jersey 07703.

Section II. DESCRIPTION AND DATA

1-4. Description

Refer to TM 11-6625-441-12 for general description and illustrations which reflect this equipment.

1-5. Tabulated Data

Refer to TM 11-6625-441-12 for tabulated data covering this equipment.

CHAPTER 2

FUNCTIONING

2-1. Application, Block Diagram Analysis

(fig. 2-1)

a. The interphone test set is used to check the serviceability of the interphone control. Block diagram analysis of the interphone test is covered in *b* below. Functioning of the receiving test circuitry, transmission test circuitry, and self-test circuitry is covered in paragraphs 2-2, 2-3, and 2-4, respectively.

b. When using the interphone test set to check an interphone control, five items of test equipment are required to provide a complete test setup: a power supply, an audio oscillator, an output meter, a multimeter, and a headset microphone.

c. The test setup simulates input and output signals and interconnections of the airborne intercommunications system in which the interphone control is used. The audio oscillator provides input and output signals to the interphone control through switching circuits of the interphone test set. The audio input signals received by the interphone control from the interphone test set are similar to signals received from a radio receiver. The output signals of the audio oscillator can also be routed through the interphone test set to the interphone control to simulate an audio input signal from a microphone for radio transmission or intercom distribution. The interphone test set also simulates the transmitter keying operation of a microphone press-to-talk switch. A headset microphone may be used as a substitute for the audio oscillator and the output meter for audio monitoring. The output meter monitors the amplified audio output power levels from the interphone control. The interphone test set switches select input and output connections to the interphone control to permit testing of each receiver, transmitter and interphone channel of the interphone control. Included in the interphone test set is a built-in capability for self-testing of its internal circuitry. The power supply provides 28 volts direct current (vdc) to the interphone test set and the interphone control being tested. The multimeter monitors the input voltage being applied to the interphone test set by the power supply.

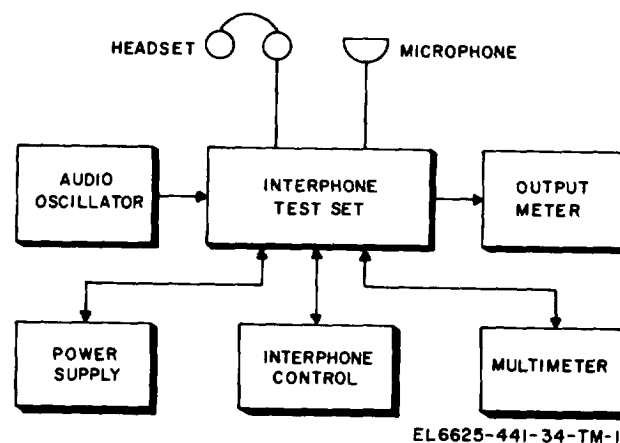

Figure 2-1. Interphone test set application, block diagram.

2-2. Receiving Test Circuit Functioning

(fig. 2-2)

NOTE

The receiving test circuitry of the interphone test set tests the nine receiver circuits and interphone audio lines of the interphone control.

a. Power to energize the interphone control is provided by a 28-volt dc power supply. The power is applied through POWER-OFF switch S7 and 1 AMP FUSE F1. FUSE F1 provides over-current protection for both the interphone test set and interphone control. OPERATE lamp 11 is connected to the power supply circuit contacts D2 and D3 of relay K1 and goes on when POWER-OFF switch S7 is placed in the POWER position.

b. An audio signal is applied to the interphone control as a simulated radio receiver output from the audio oscillator, and enters the interphone test set at AUDIO OSC jacks J1 and J2. The signal is applied through contacts C2 and C3 of relay K1 to INPUT SEL switch S3. When testing the receiver circuits of an interphone control, INPUT SEL switch S3 is placed in R (receive); the audio signal developed across load resistor R3 is applied to the wiper contact of RECEIVER SEL switch S4.

c. RECEIVER SEL switch S4 routes the audio signal to the selected receiver channel of the interphone control (positions 1 through 7, IN-

TER, and EMER of S4; EMER position is only applicable to Test Set. Radio TS-1588A/AIC) undergoing testing. The headset high output from the interphone control (terminal 5 of J1) is applied through contact R (receive) of OUTPUT SEL switch S2 and to contact 2 of SIGNAL switch S6. With SIGNAL switch S6 in the spring loaded METER position, the audio high output signal is applied across contacts A2 and A3 of relay K1 to OUTPUT MTR jack J4, and to the output meter which monitors the audio output signal of headset amplifier A2. When SIGNAL switch S6 is placed in the HD MIC position, the audio output signal of headset amplifier A2 is applied to HDST MIC jack J7 through contacts B2 and B3 to relay K1.

d. When testing the interphone audio circuits of an interphone control, INPUT SEL switch S3 is placed in the R (receive) position and RECEIVER SEL switch S4 is placed in the INTER position. The audio signal developed across load resistor R3 is applied to the wiper contact of RECEIVER SEL switch S4, through the INTER position to the interphone line (terminal 8 of J1) and the private interphone line (terminal 6 of J1) of the interphone control. The audio output signal of headset amplifier A2 is then applied through OUTPUT SEL switch S2 and through SIGNAL switch S6, through con-

tacts A2 and A3 of relay K1 to OUTPUT MTR jack J4, or contacts B2 and B3 of relay K1 to HDST MIC jack J7 for monitoring.

NOTE

The procedure in e below can only be performed using Test Set, Radio TS-1588A/AIC.

e. When testing the emergency receiver audio circuitry of the interphone control, INPUT SEL switch S3 is placed in the R (receive) position and RECEIVER SEL switch S4 is placed in the EMER position. The audio signal developed across load resistor R3 is applied to the wiper contact of RECEIVER SEL switch S4 through the EMER position to the emergency receiver audio line (terminal 27 of J1) of the interphone control. The audio output signal of headset amplifier A2 is then applied through OUTPUT SEL switch S2 and through SIGNAL switch S6, through contacts A2 and A3 of relay K1 to OUTPUT MTR jack J4, or contacts B2 and B3 of relay K1 to HDST MIC jack J7 for monitoring.

f. When INPUT SEL switch S3 and OUTPUT SEL switch S2 are placed to the I position, the audio output signal from the audio oscillator is routed through OUTPUT SEL switch S2 to SIGNAL switch S6 and to OUTPUT MTR jack J4 where voltage measurements of the audio oscillator signal can be made.

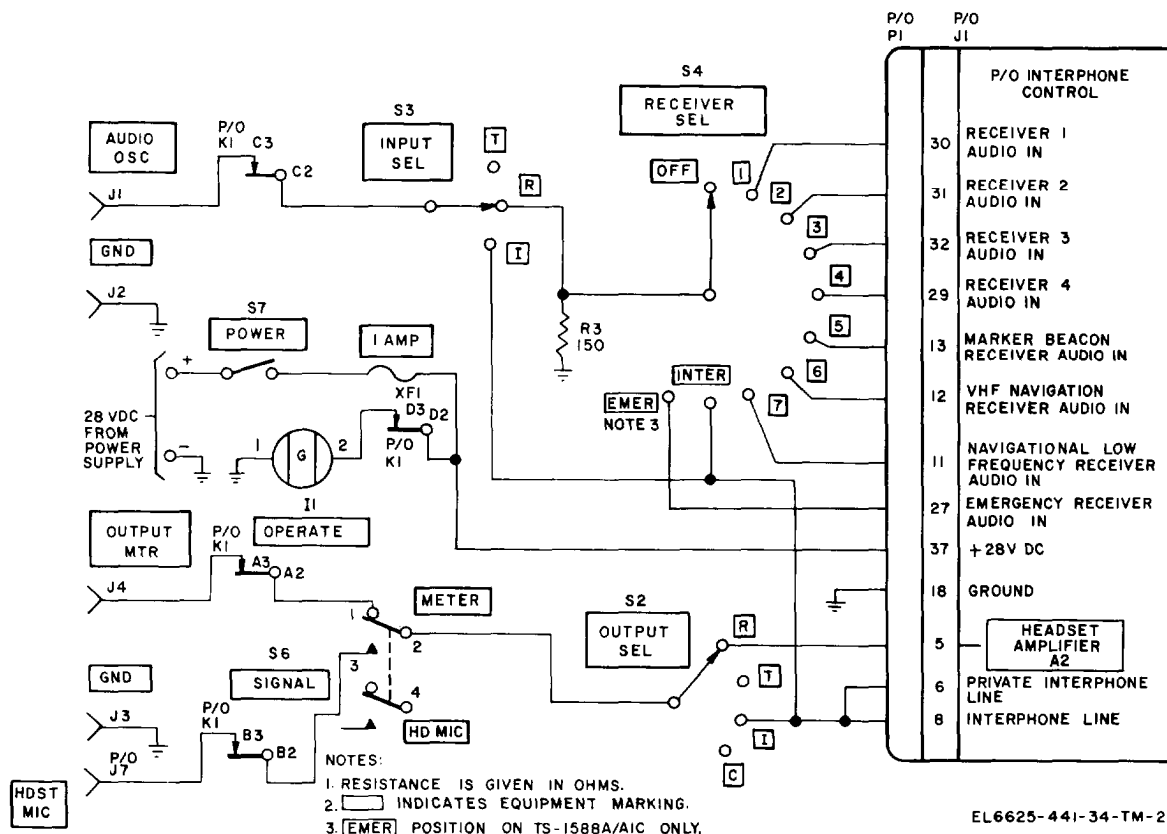

Figure 2-2. Interphone test set, receiving test circuit, simplified schematic diagram.

2-3. Transmission Test Circuit Functioning
 (fig. 2-3)

NOTE

Application of 28-volt dc power to energize the interphone control is described in paragraph 2-2a.

Transmitting test circuitry of the interphone test set tests the transmitter output and control circuits of the interphone control.

a. The audio input signal to the interphone control is provided by either the audio oscillator or the microphone. Microphone audio input signals are applied direct to terminal 3 of J 1 through contacts 6 and 5 of SIGNAL switch S6 when held in the HD MIC position. The audio oscillator input signal is applied to INPUT SEL switch S3 through contacts C2 and C3 of relay K1. When switch S3 is in the T position the audio oscillator input signal is applied to load resistors R1 and R2. The audio signal developed across R1 is applied through contacts 4 and S of SIGNAL switch S6 (in METER position) to terminal 3 of J1, and into microphone preamplifier A3 of the

interphone control. However, transmission cannot be accomplished until KEYING switch S1 is placed in either the RADIO or INTER position. When switch S1 is in the RADIO position, a ground is made to the transmitter control circuitry of the interphone control through terminal 15 of J1. When switch S1 is in the INTER position, interphone relay K1 of the interphone control is energized completing the interphone transmitting circuits of the interphone control.

b. The transmitter audio output signal from the interphone control is applied direct to S5B of TRANSMITTER SEL switch S5, and to contact T of OUTPUT SEL switch S2. When switch S2 is in the T position, and switch S6 is in the METER position, the audio output signal is applied to the output meter. When switch S2 is in the T position and switch S6 is in the HD MIC position, the audio output signal is routed to HDST MIC jack J7 and into the headset. When testing the audio output signal sidetone from the interphone control, switch S2 is in R and switch S4 is in INTER. When switch S1 is placed and held in

INTER, interphone relay K1 of the interphone control energizes, and when switch S6 is placed and held in HD MIC, a voice signal spoken into the mike is applied direct to interphone relay K into headset amplifier A2. Headset amplifier A2 audio output is applied across terminals 5, 8, and 23 of J1. Terminal 5 audio output signal is applied to the R position of switch S2 and then to contacts 2 and 3 of switch S6, across contacts B2 and B3 of interphone test set relay K1 and into the headset; simultaneous with the activity of terminal 5 audio output signal, terminal 8 audio output signal is applied to the INTER contact of

switch S4, across load resistor R3 and to ground; terminal 23 audio output signal is applied direct to the headset.

c. To operate the transmitter control circuits of the interphone control, 28 Vdc power is applied to S5A of switch S5 through switch S7, fuse F1 and lamp 13. When switch S5 is placed to positions 1 through 4 on TS-1588/AIC and 1 through ALTN on TS-1588A/AIC, and switch S1 is placed and held in RADIO, the transmitter control circuits are energized and lamp 13 goes on, indicating that the keying operation is being accomplished.

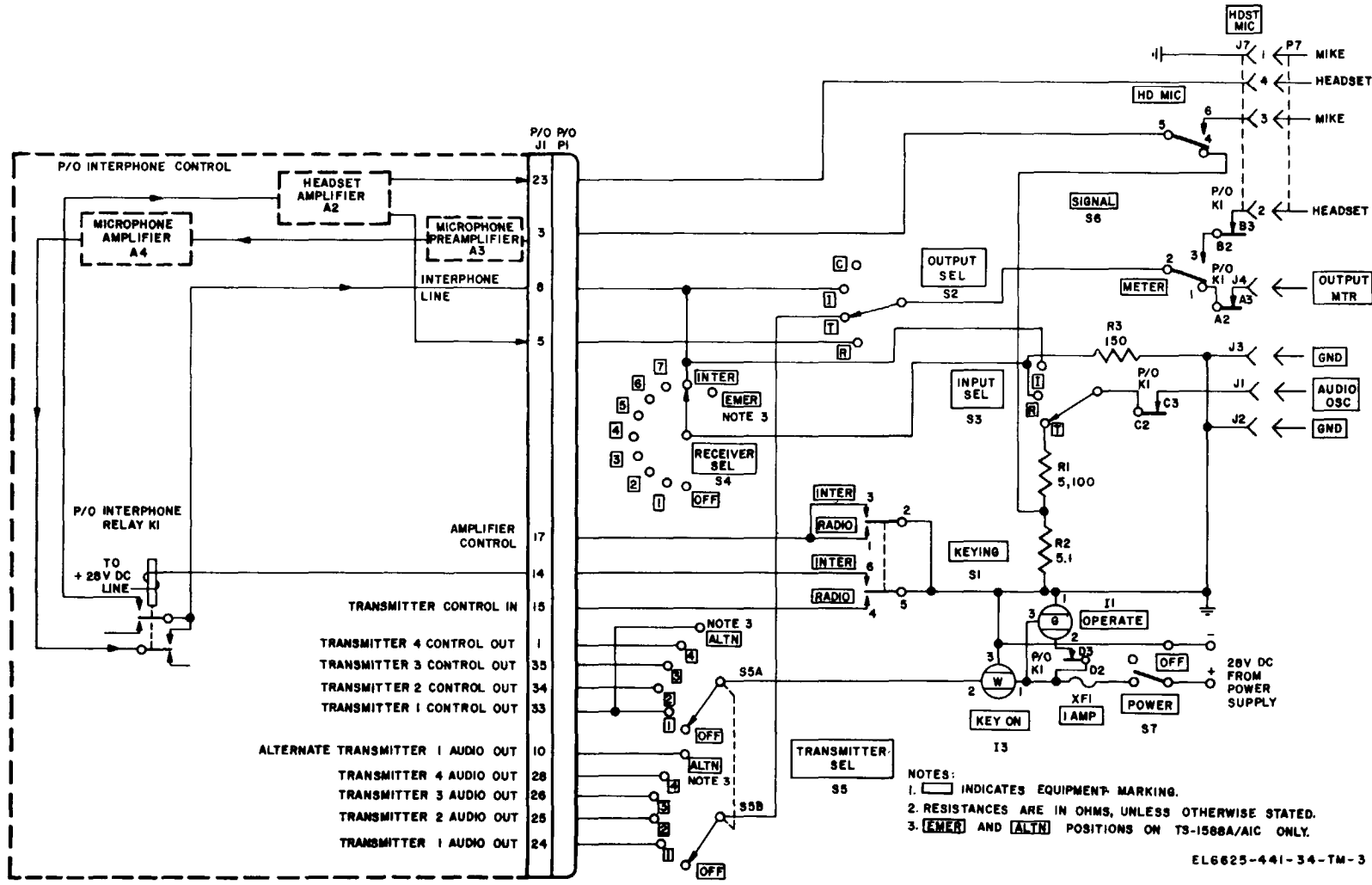

Figure 2-3. Interphone test set, transmission test circuits, simplified schematic diagram.

2-4. Self-Test Circuit Functioning

(fig. FO-2)

The self-test circuits check the performance of the receiver and transmitter circuits and controls of the interphone test set. The self-test check is accomplished through the use of SELF TEST RECEPTACLE J8, relay K1, test cable connector P1, and the placement of toggle and selector switches to predetermined positions. During self-test operation, the interphone test set is connected to a 28-volt dc power supply, and test cable connector P1 is connected to SELF TEST RECEPTACLE J8.

a. Power to energize relay K1 is obtained through switch S7, fuse F1, and pins 37 and 20 of test cable connector P1, through relay K1, pins 4 and 19 of connector P1, and to ground. When relay K1 energizes, lamp 11 goes out, contacts D1 and D2 of relay K1 close, allowing current to flow through lamp 12 to ground, lighting the lamp. Contacts B1 and B2, and C1 and C2 also close, thus completing the self-test circuits.

b. Proper operation of the interphone test set during the self-test check is verified by the lighting and going out of lamp 13 when switches S1 through S5 are placed in various position combinations.

CHAPTER 3

DIRECT SUPPORT MAINTENANCE

Section 1. GENERAL

3-1. General Instructions

Troubleshooting at direct support maintenance includes all the techniques outlined for organizational maintenance and any special or additional techniques required to isolate a defective part. Direct support maintenance procedures are not complete in themselves but supplement the procedures described in TM 11-6625-441-12. The systematic troubleshooting procedure which begins with the operational and sectionalization checks that can be performed at organizational maintenance must be completed by systematic troubleshooting techniques. Paragraphs 3-4 and 3-5 describe these systematic troubleshooting techniques.

3-2. Organization of Troubleshooting Procedures

a. General. Troubleshooting the interphone test set consists of localization, which means tracing the fault to a defective part responsible for the abnormal condition. Some faults, such as burned-out resistors and shorted wires, can often be located by sight and smell. The majority of faults, however, must be localized by checking voltages and resistance.

b. Localization. The tests listed below will aid in isolating the trouble. First, localize the trouble to a single circuit, and then isolate the trouble within that circuit by voltage, resistance, and continuity measurements.

(1) *Visual inspection.* The purpose of visual

inspection is to locate faults without testing or measuring the circuits. All meter readings or other visual signs should be observed and an attempt made to localize the fault to a particular item.

(2) *Operational tests.* Operational tests frequently indicate the general location of trouble. In many instances, the tests will help in determining the exact nature of the fault. The equipment self-test procedure (TM 11-6625-441-12) is a good operational test.

(3) *Voltage and resistance measurements.* Follow the procedures given in paragraph 3-4 and compare the values given in that paragraph with the readings taken.

(4) *Troubleshooting charts.* The trouble symptoms listed in table 3-1 (TS-1588/AIC) and table 3-2 (TS-1588A/AIC) will aid in localizing trouble to a component part.

(5) *Intermittent troubles.* In all these tests, the possibility of intermittent troubles should not be overlooked. If present, this type of trouble often may be made to appear by tapping or jarring the equipment. Check the wiring and connections to the components of the interphone test set.

3-3. Tools and Test Equipment Required

Tool Kit, Electronic Equipment TK-105/G and Multimeter TS-352 (*)/U(multimeter) are the only items of tool and test equipment required to troubleshoot and repair the interphone test set.

Section II. TROUBLESHOOTING

3-4. Voltage and Resistance Measurements

(fig. FO-4)

a. Preparation.

(1) Remove the cover from the interphone test set case by sliding the cover off the hinge pins.

(2) Loosen the captive screws across the top and bottom of the front panel and remove the interphone test set chassis from the case.

b. Resistance Measurements.

CAUTION

DO NOT apply power to the interphone test set when making resistance measurements.

(1) Connect the multimeter test probes to +28V and the GND binding posts on the interphone test set front panel. The multimeter should indicate approximately 700 ohms. If the

resistance is zero, check the +28-volt dc circuit wiring for shorts.

(2) Disconnect the multimeter test probes from the +28V and the GND binding posts and connect the test probes to the AUDIO OSC and the GND binding posts. Rotate INPUT SEL switch S3 to T. The multimeter should indicate approximately 5,000 ohms. If the resistance is low, check resistors R2 and R3. If the resistance is zero, check the AUDIO OSC. circuit for shorts.

(3) Rotate the INPUT SEL switch S3 to R. The multimeter should indicate 150 ohms. If the resistance is low, check resistor R3. If the resistance is zero, check the AUDIO OSC circuit for shorts.

(4) Leave one multimeter test probe in the GND binding post and connect the other test probe to contact pin 3 of plug P1. The multimeter should indicate 5 ohms. If the resistance is low, check resistor R2. If the resistance is zero, check pin 3 of P1 for a short circuit to ground.

(5) Disconnect the multimeter test probes from pin 3 of plug P1 and the GND binding post.

c. Voltage Measurement

WARNING

28 VOLTS DC, 1 AMPERE is exposed when the interphone test set chassis is removed from its case.

(1) Set multimeter to indicate dc volts.

(2) Connect the multimeter test probes to the +28 V and GND binding posts on the interphone test set front panel.

(3) Connect the interphone test set power cable to a 27.5 + 0.5 volts dc power source.

(4) Connect the red insulated battery clip to the plus side of the line, and the black insulated clip to the ground side.

(5) The multirneter must indicate 27.5 + 0.5 volts dc when POWER-OFF switch S7 is set to

POWER. If the voltage is higher or lower than 27.5 + 0.5 volts dc, then readjust the output of the power supply for the correct voltage.

3-5. Troubleshooting of Interphone Test Set

a. General. Troubleshooting tables 3-1 and 3-2 outline procedures for localizing troubles to a specific part within the interphone test set. Refer to figures 3-1 through 3-4 for parts locations. When voltage and/or resistance measurements are required refer to paragraph 3-4.

b. Use of Troubleshooting Table. The troubleshooting tables supplement the equipment self-test procedure (TM 11-6625-441-12). If previous self-tests have resulted in reference to a particular malfunction then go directly to that item in the table. Table 3-1 covers troubleshooting information for the TS-1588/AIC and table 3-2 provides troubleshooting information for the TS-1588A/AIC. If no known symptoms are available, then begin troubleshooting by performing the equipment self -test procedure until a symptom occurs. Locate the symptom under the malfunction column of the troubleshooting table and find the probable cause and corrective act ion next to the particular symptom.

CAUTION

If operational symptoms indicate the possibility of short circuits within the interphone test set, make the resistance measurements described in paragraph 3-4 *b* before applying power to the equipment.

c. Repair Procedures. Repair procedures for the interphone test set are contained in paragraphs 3-6 through 3-12.

d. Direct Support Testing. Testing instructions which must be performed after any repairs are made are contained in paragraph 3-13.

Table 3-1. Troubleshooting of Tes t Set, Radio TS-1588/AIC.

<i>Malfuncwn</i>	<i>Probable cause</i>	<i>Corrective action</i>
1. OPERATE lamp DS1 fails to go on when POWER-OFF switch S7 is set to POWER.	No dc power applied to interphone test Set. Defective lamp DS 1. Defective lampholder XDS1. Defective fuse F1. Defective fuseholder XF1. Defective POWER switch S7. Defective self-test relay K1. Defective wiring.	Check connections to power source. Replace defective lamp DS1. Replace lamoholder XDS1 (fig. 3-1). Replace fuse F1. Replace fuseholder XF1. Replace switch S7. Replace relay K1. Repair or replace defective wiring.
2. SELF TEST lamp DS2 fails to go on and OPERATE lamp DS1 fails to go out when SELF TEST RECEPTACLE J8 is mated with test cable plug P1.	Defective self-test relay K1. Defective SELF TEST RECEP-TACLE J8. Defective test cable plug P1. Defective wiring,	Replace relay K 1. Replace receptacle J8 (fig. 3-2). Repair or replace plug P1. Repair or replace defective wiring

Table 3-I. Troubleshooting of Test Set, Radio T'S-1588/AZC-Continuad.

<i>Malfunction</i>	<i>Probable cause</i>	<i>Corrective action</i>
3. SELF TEST lamp DS2 fails to go on and OPERATE lamp DS 1 goes out when test cable plug PI is plugged into SELF TEST RECEPTACLE J8.	Defective lamp DS2. Defective lampholder XDS2. Defective wiring.	Replace lamp DS2. Replace lampholder XDS2 (fig. 3-1). Repair or replace defective wiring.
4. KEY ON lamp DS3 fails to go on when KEYING switch S 1 is held at either INTER or RADIO, RECEIVER SEL switch S4 set to OFF, TRANSMITTER SEL switch S5 set to 1, both INPUT SEL switch S3 and OUTPUT SEL switch S2 set to R.	Defective lamp DS3, Defective lampholder XDS3. Defective KEYING switch S1. Defective TRANSMITTER SEL switch S5, Defective wiring,	Replace lamp DS3. Replace lampholder XDS3. Replace switch S1. Replace switch S5 (fig. 3-2). Repair or replace defective wiring.
5. KEY ON lamp DS3 fails to go on when TRANSMITTER SEL switch S5 is set, in turn, to 2, 3, and 4, with remaining switches set as in step 4 above.	Defective lamp DS3. Defective lampholder XDS3. Defective TRANSMITTER SEL switch S5. Defective KEYING switch S1. Defective wiring.	Replace lamp DS3. Replace lampholder XDS3 (fig. 3-1). Replace switch S5 (fig. 3-2). Replace switch S1 (fig. 3-1). Repair or replace defective wiring.
6. KEY ON lamp DS3 fails to go on when SIGNAL switch S6 is held at HD MIC, TRANSMITTER SEL switch S5 set to 4, RECEIVER SEL switch S4 set to OFF, and both INPUT SEL switch S3 and OUTPUT SEL switch S2 set to R.	Defective lamp DS3. Defective lampholder XDS3. Defective SIGNAL switch S6. Defective TRANSMITTER SEL switch S5. Defective OUTPUT SEL switch S2. Defective wiring.	Replace lamp DS3. Replace lampholder XDS3. Replace switch S6. Replace switch S5 (fig. 3-2). Replace switch S2 (fig. 3-1). Repair or replace defective wiring.
7. KEY ON lamp DS3 fails to go on when SIGNAL switch S6 is held at HD MIC, OUTPUT SEL switch S2 is set to I, and remaining switches set as in step 6, above.	Defective lamp DS3. Defective lampholder XDS3. Defective OUTPUT SEL switch S2. Defective SIGNAL switch S6. Defective TRANSMITTER SEL switch S5. Defective wiring.	Replace lamp D.S3. Replace lampholder XDS3. Replace switch S2. Replace switch S6. Replace switch S5 (fig. 3-2). Repair or replace defective wiring.
8. KEY ON lamp DS3 fails to go on when SIGNAL switch S6 is held at HD MIC OUTPUT SEL, switch S2 set at T, and TRANSMITTER SEL switch S5 set, in turn, 3, 2, and 1.	Defective lamp DS3. Defective lampholder XDS3. Defective SIGNAL switch S6. Defective TRANSMITTER SEL switch S5. Defective OUTPUT SEL switch S2. Defective wiring.	Replace lamp DS3 (fig. 3-1). Replace lampholder XDS3. Replace switch S6. Replace switch S5 (fig. 3-2). Replace switch S2 (fig. 3-1). Repair or replace defective wiring.
9. KEY ON lamp DS3 fails to go on when TRANSMITTER SEL switch S5 is set to 1 and RECEIVER SEL switch S4 is rotated from 1 through INTER,	Defective lamp DS3, Defective lampholder XDS3. Defective TRANSMITTER SEL switch S5. Defective RECEIVER SEL switch S4. Defective wiring.	Replace lamp DS3. Replace lampholder XDS3. Replace switch S5 (fig. 3-2). Replace switch S4. Repair or replace defective wiring.
10. KEY ON lamp DS3 fails to go on when INPUT SEL switch S3 is set to I, TRANSMITTER SEL switch S5 set to 1, OUTPUT SEL switch set to R, and RECEIVER SEL switch S4 set to OFF.	Defective lamp DS3, Defective lampholder XDS3. Defective TRANSMITTER SEL switch S5. Defective INPUT SEL switch S3. Defective wiring.	Replace lamp DS3. Replace lampholder XDS3 (fig. 3-1). Replace switch S5 (fig. 3-2). Replace switch S3 (fig. 3-1). Repair or replace defective wiring.
11. KEY ON lamp DS3 goes on when INPUT SEL switch S3 is set to T with remaining switches set as in step 10 above,	Defective INPUT SEL switch S3. Defective wiring.	Replace switch S3. Repair or replace defective wiring.
12. SELF TEST lamp DS2 fails to go out and OPERATE lamp DS1 fails to go on when test cable plug P1 is disconnected from SELF TEST RECEPTACLE J8.	Defective self-test relay K1. Defective wiring.	Replace relay K1. Repair or replace defective wiring.

Table 3-1. Troubleshooting of Test Set, Radio TS-1588/AIC- Continued,

Malfunction	Probable cause	Corrective action
13. SELF TEST lamp DS2 goes out and OPERATE lamp DS1 fails to go on when test cable plug P1 is disconnected from SELF TEST RECEPTACLE J8.	Defective OPERATE lamp DS1. Defective lampholder XDS1. Defective wiring.	Replace lamp DS1. Replace lampholder XDS1. Repair or replace defective wiring.

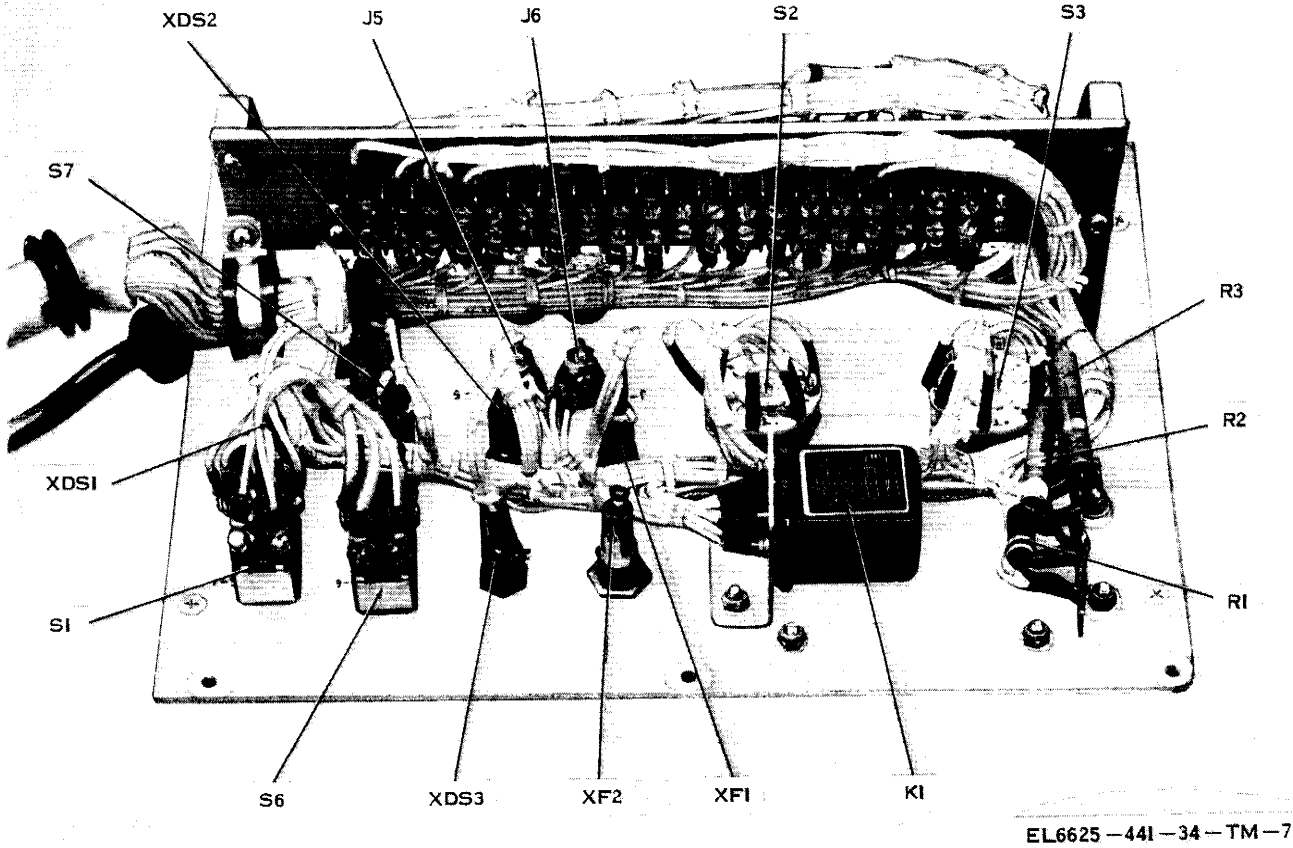

EL6625-441-34-TM-7

Figure 3-1. Test Set, Radio TS-1588/AIC, upper front panel- parts location.

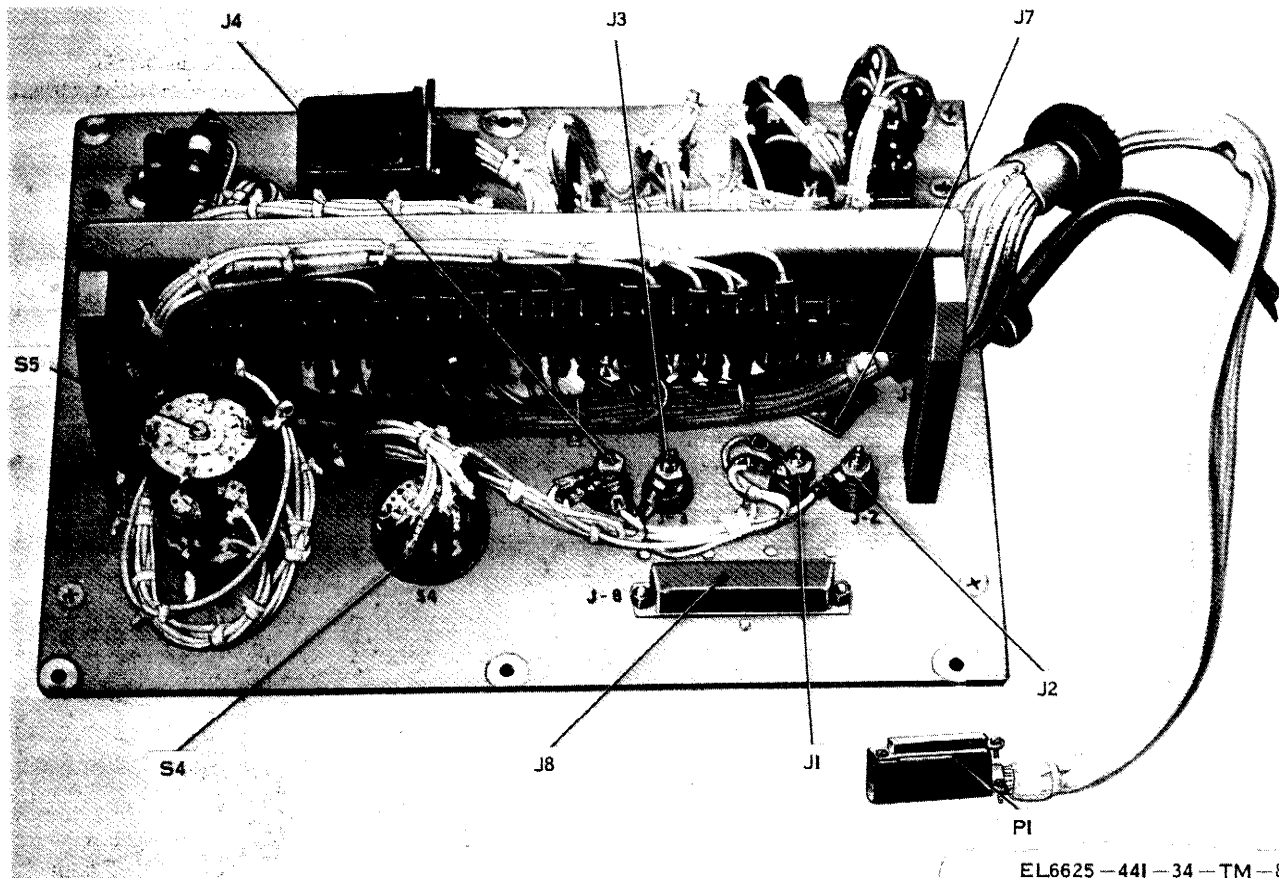

Figure 3-2. Test Set, Radio TS-1588/AIC, lower front panel, parts location

EL6625-441-34-TM-8

Table 3-2. Troubleshooting of Test Set, Radio TS-1588A/AIC.

Malfunction	Probable cause	Corrective action
1. OPERATE lamp 11 fails to light when POWER-OFF switch S7 is in POWER position.	Power source not being received by interphone test set, OPERATE lamp 11 Lampholder Fuse F1 Switch S7 Relay K1 Wiring	Check power source connections. Replace lamp. Replace lampholder, Replace fuse. Replace switch. Replace relay. Repair or replace wiring.
2. SELF TEST lamp 12 fails to light and OPERATE lamp 13 fails to go out when SELF TEST RECEPTACLE J8 is mated with test cable connector P1.	Receptacle J8 Connector P1 Relay K1 Wiring Lamp 12 Lamp holder	Repair or replace receptacle. Repair or replace connector. Replace relay. Repair or replace wiring. Replace lamp. Replace lampholder.
3. KEY ON lamp 13 fails to light when KEYING switch S1 is held in either RADIO or INTER, with RECEIVER SEL switch S4 in OFF, TRANSMITTER SEL switch S5 in 1, and both INPUT SEL switch S3 and OUTPUT SEL switch S2 in R.	Lamp 13 Lampholder Switch S1 Switches S2, S3, and S5 Wiring	Replace lamp. Replace lampholder. Replace switch. Replace switch. Repair or replace wiring.

Table 3-2. Troubleshooting of Test Set, Radio TS- 1588A/AIC- Continued.

<i>Malfunction</i>	<i>Probable cause</i>	<i>Corrective action</i>
4. Repeat of step 3 except TRANSMITTER SEL switch S5 is in positions 2, 3, 4 and ALTN.	Same as step 3.	Same as step 3.
5. KEY ON lamp 13 fails to light when SIGNAL switch S6, is held in HD MIC, and remaining switch positions as in step 3.	Lamp 13 Lamp holder Switch S6 Switch S5 Switch S2 Wiring	Replace lamp. Replace lampholder. Replace switch. Replace switch. Replace switch. Repair or replace wiring.
6. Same as step 5 except OUTPUT SEL switch S2 is placed to I, C, and T, end remaining switches as in step 5.	Same as step 5.	Same as step 5.
7. KEY ON lamp 13 fails to light when SIGNAL switch S6 is held in HD MIC, with OUTPUT SEL switch at T. TRANSMITTER SEL switch S5 in 4, 3, 2, and 1.	Same as step 5.	Same as step 5.
8. KEY ON lamp 13 fails to light when RECEIVER SEL switch S4 is in positions 1 through EMER, with TRANSMITTER SEL switch S5 in 1.	Lamp 13 Lampholder Switch S5 Switch S4 Wiring	Replace lamp. Replace lampholder. Replace switch. Replace switch. Repair or replace wiring.
9. KEY ON lamp 13 fails to light when RECEIVER SEL switch S4 is OFF, OUTPUT SEL switch S2 is in R, INPUT SEL switch S3 is in 1, and TRANSMITTER SEL switch S5 is in 1.	Lamp 13 Lampholder Switch S5 Switch S3 Wiring	Replace lamp. Replace lampholder. Replace switch. Replace switch. Repair or replace wiring.
10. KEY ON lamp 13 fails to go out and remain out when switches are as in step 10 and INPUT SEL switch S3 is in R and T.	Switch S3 Wiring	Replace switch. Repair or replace wiring.
11. SELF TEST lamp 12 fails to go out and OPERATE lamp 11 fails to light when test cable connector P1 is disconnected from SELF TEST RECEPTACLE J8.	Lamp 11 Lampholder Relay K 1 Wiring	Replace lamp. Replace lampholder. Replace relay. Repair or replace wiring.
12. OPERATE lamp 11 fails to go out when POWER-OFF switch S7 is in OFF.	Switch S7 Wiring	Replace switch. Repair or replace wiring.

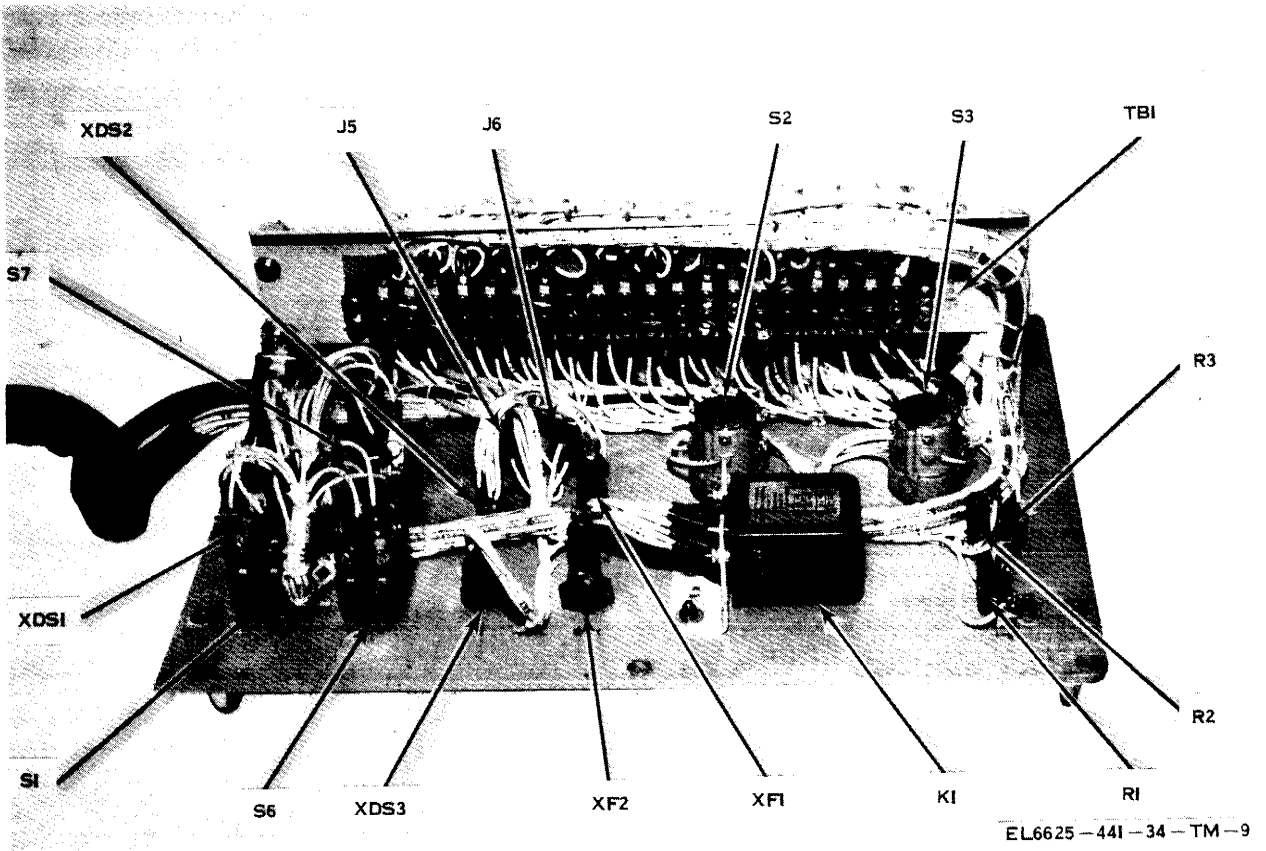
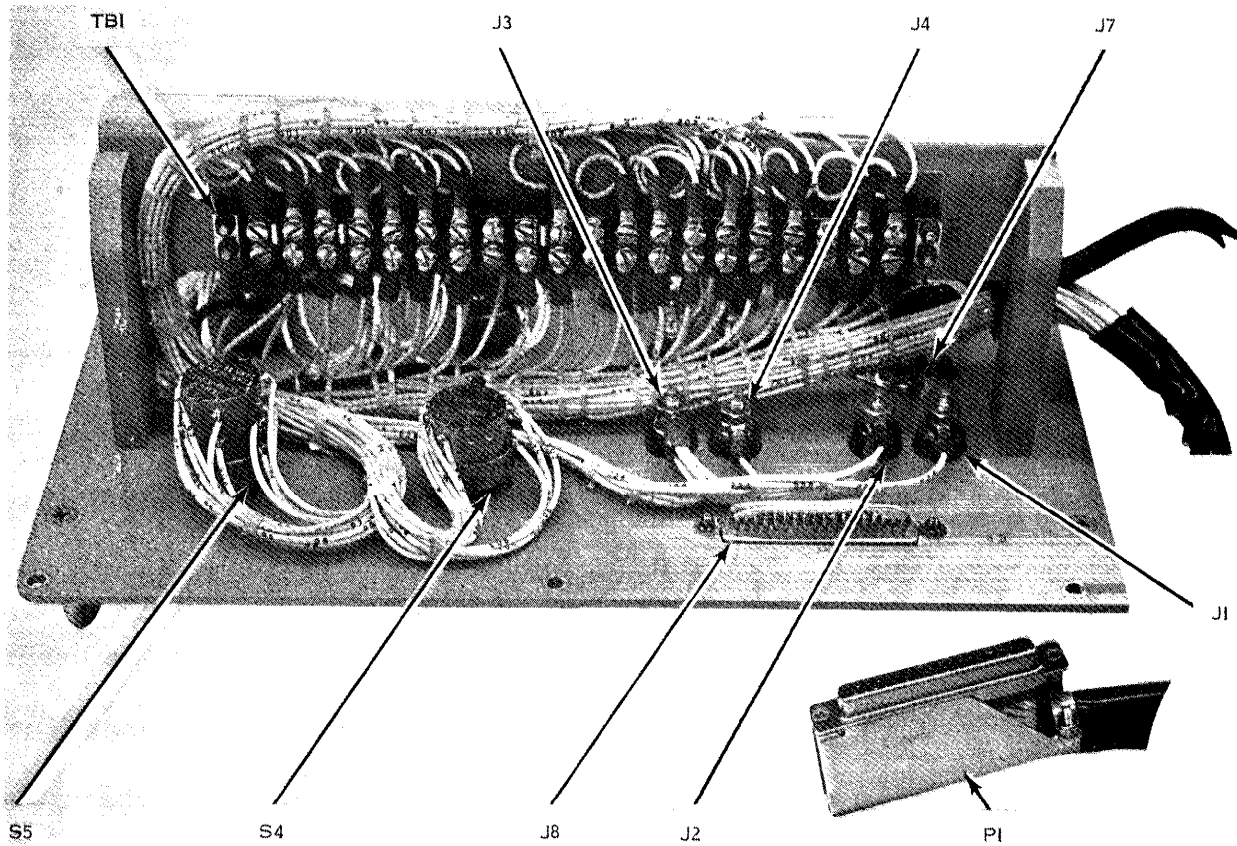

Figure 3-3. Test Set, Radio TS-1588A/AIC, upper front panel,



EL66.25--441--34--TM--10

Figure 3-4, Test Set, Radio TS-1588A/AIC, lower front panel, parts location.

Section III. MAINTENANCE OF TEST SET, RADIO TS-1588(*)/ AIC

3-6, General

a. All of the parts of the interphone test set can be reached and replaced after the interphone test set chassis is removed from its case (*b* below). When replacing wiring, refer to the interphone test set wiring diagram (fig. FO-4).

b. Remove the interphone test set chassis from the case as follows:

(1) Remove the cover from the interphone test set case by sliding the cover off the hinge pins.

(2) Loosen the captive screws across the top and bottom of the front panel and lift the front panel and chassis from the case,

c. Replace the interphone test set chassis into the case as follows:

(1) Carefully place the front panel and chassis into the case. Make sure that neither of

the cables is pinched between the front panel and the case.

(2) Align the captive screws with the threaded portions of the case and tighten. Be careful not to overtighten the screws which could distort the case and/or the front panel.

(3) Slide the cover onto the hinge pins; close and latch the cover.

3-7. Repair of Hinges and Replacement of Hinges, Latches, and Handle

a. *Repair of Bent Hinge Pins*. If a hinge pin becomes bent, remove the cover and straighten the pin with a pair of pliers. If the pin is too badly bent and cannot be straightened, then replace the defective hinge (*b* below).

h. *Replacement of Hinges, Latches and Handle*. Replace a defective hinge, latch, or handle as follows:

- (1) Select a drill bit of appropriate size to drill out the rivets holding the defective item.
- (2) Remove the defective hinge, latch or handle.
- (3) Replace the defective item with a new one.
- (4) Hold in place with new rivets.

3-8. Removal and Replacement of Switches

a. Removal.

(1) Remove the interphone test set chassis from the case by following the instructions contained in paragraph 3-6 b.

(2) Tag and solder all wires connecting to the switch. Be careful not to burn the insulation covering the wire.

(3) Remove and retain the hexagonal mounting nut which secures the switch to the interphone test set panel.

(4) Remove the switch.

b. Replacement.

(1) Refer to figure FO-4 and solder jumpers to the switch as required.

(2) Use the hardware removed in a (3) above to secure the switch to the interphone test set panel.

CAUTION

Be careful not to burn insulation, use excessive solder, or drop solder beads into the switch as this may cause conduction between switch contacts.

(3) Connect and solder the wires removed in a (2) above to the correct contacts of the new switch by following the tag instructions.

(4) Replace the interphone test set chassis into the case by following the instructions contained in paragraph 3-6c.

3-9. Removal and Replacement of Relay K1

a. Removal.

(1) Remove the interphone test set chassis from the case by following the instructions contained in paragraph 3-6 b.

(2) Tag and unsolder all wires connected to relay K1.

(3) Remove and retain hardware securing relay K1 to its mounting bracket.

(5) Remove the relay.

b. Replacement.

(1) Secure the replacement relay K1 to its mounting bracket with the hardware removed in a (3) above.

(2) Connect and solder the wires removed in a (2) above to the correct pins following the tag instructions and figure FO-4.

(3) Replace the interphone test set chassis in

the case by following the instructions contained in paragraph 3-6 c.

3-10. Removal and Replacement of Lampholders

a. Removal.

(1) Remove the interphone test set chassis from the case by following the instructions contained in paragraph 3-6 b.

(2) Tag and unsolder the wires connected to the lampholder.

(3) Remove and retain the indicator lens, lamp and hexagonal mounting nut from the lampholder.

(4) Remove the lampholder from the front panel.

(5) Remove and retain the hexagonal mounting nut on the lampholder.

b. Replacement.

(1) Replace the hexagonal mounting nut removed in a (5) above on the new lampholder. A mounting nut is not supplied with the item.

(2) Place the new lampholder through the appropriate hole in the interphone test set front panel and secure with the hexagonal mounting nut removed in a (3) above.

(3) Connect and solder the wires removed in a (2) above following the tag instructions and figure FO-4.

(4) Place the lamp and lens removed in a (3) above on the lampholder.

(5) Replace the interphone test set chassis into the case by following the instructions contained in paragraph 3-6c.

3-11. Removal and Replacement of Fuseholders

a. Removal.

(1) Remove the interphone test set chassis from the case by following the instructions contained in paragraph 3-6 b.

(2) Remove and retain the fuseholder cap and fuse.

(3) Tag and unsolder the wires connected to the fuseholder.

(4) Remove the hexagonal mounting nut which secures the fuseholder to the interphone test set panel.

(5) Remove the fuseholder.

b. Replacement.

(1) Use the hexagonal mounting nut removed in a (4) above to secure the fuseholder to the interphone test set panel. If the new fuseholder has a hexagonal mounting nut with it, then dispose of the nut which was retained.

(2) Connect and solder the wires removed in a (3) above following the tag instructions and figure FO-4.

(3) Place the fuse and fuseholder cap, removed in *a* (2) above into the fuseholder.

(4) Replace the interphone test set chassis in the case by following the instructions contained in paragraph 3-6 *c*.

3-12. Removal and Replacement of Terminal Boards

a. Removal.

(1) Remove the interphone test set chassis from the case by following the instructions contained in paragraph 3-6b.

(2) Tag and remove all wires and/or components connected to the terminal board.

(3) Remove and retain the hardware which secures the terminal board to the interphone test set panel.

(4) Remove the terminal board; retain the strip marker if one is used.

b. Replacement.

(1) Use the hardware removed in *a* (3) above to secure the new terminal board to the interphone test set panel. Make sure that the strip marker is placed properly if used and is visible.

(2) Connect wires and/or components to the terminal board following the tag information and figure FO-4.

(3) Replace the interphone test set chassis in the case by following the instructions given in paragraph 3-6 *c*.

3-13. Direct Support Test Procedures

After repairs have been made to the interphone test set, the self-test procedure (TM 11-6625-441-12) must be performed prior to returning equipment to the user or stock.

CHAPTER 4

GENERAL SUPPORT MAINTENANCE AND TESTING PROCEDURES

4-1. General

a. General support maintenance is the same as for direct support. This category of maintenance includes all the organizational maintenance found in TM 11-6625-441-12 and the direct support procedures found in chapter 3. Also, the general support testing procedures will allow a more detailed and complete check of the interphone test set,

b. Testing procedures are prepared for use by electronic field maintenance shops and service organizations responsible for general support maintenance of electronic equipment to determine the acceptability of repaired electronic equipment. The procedures set forth specific requirements that repaired electronic equipment *must* meet before it is returned to the using organization.

c. Comply with the instructions preceding the body of each test. Perform each test in sequence. Do not vary the sequence. For each step, perform all the actions required in the *Test equipment control settings* and *Equipment under test*

control settings columns; then perform each specific test procedure and verify it against its performance standard.

4-2. Tools and Test Equipment Required for General Support

The test equipment and tools required to perform the general support testing procedures given in this chapter are listed below.

a. *Test Equipment.* The only test equipment required to perform the tests in this chapter is Multimeter, John Fluke Co., Inc., Model 8100, (NSN 6625-00-480-5702) (or equivalent).

b. *Tools.* All tools required to perform tests in this chapter are contained in Tool Kit, Electronic Equipment TK-105/G.

4-3. Physical Tests and Inspections

a. *Test Equipment and Materials.* None required.

b. *Test Connections and Conditions.*

(1) No connections necessary.

(2) Remove the cover from the interphone test set and remove the interphone test set chassis from its case.

c. Procedure.

<i>Step No.</i>	<i>Test equipment control settings</i>	<i>Equipment under test control settings</i>	<i>Test procedures</i>	<i>Performance standard</i>
1.	None.	Control may be in any position.	<p>a. Inspect case, cover and chassis for: damage or missing parts, security and serviceability of latches, handle, and hinges, condition of paint.</p> <p style="text-align: center;">NOTE</p> <p>Touchup painting is recommended in lieu of refinishing whenever practicable; screwheads, binding posts, receptacles, and other plated parts will not be painted or polished with abrasives.</p> <p>b. Inspect all controls and mechanical assemblies for loose or missing screws, bolts, and nuts.</p> <p>c. Inspect all connectors, clips, lamp holders, fuse holders, and cables for looseness, damage or missing parts.</p>	<p>a. No damage evident or parts missing. All parts secure and serviceable. External surf aces to be painted will not show bare metal. Panel lettering will be legible.</p> <p>b. Screws, bolts, and nuts will be tight. None will be missing.</p> <p>c. No loose or damaged parts. No missing parts.</p>
2.	None.	Controls may be in any position.	<p>a. Rotate all panel controls throughout their limits of rotation.</p> <p>b. Operate all switches.</p>	<p>a. Controls will rotate freely without binding or excessive looseness.</p> <p>b. Switches will operate properly without evidence of damage.</p>

4-4. Resistance Check
(fig. 4-1)

a. Test Equipment and Materials. John Fluke Multimeter Model 8100 is required to perform and accomplish the resistance check on the interphone test set. No special materials are needed.

b. Preparation.

- (1) Remove the cover from the interphone test set.
- (2) Connect the Model 8100 to the interphone test set as shown in figure 4-1.

c. Procedure

<i>Step No.</i>	<i>Test equipment control settings</i>	<i>Equipment under test control settings</i>	<i>Test procedures</i>	<i>Performance standard</i>
1.	a. KW Depressed. b. RANGE: 1.	Controls in any position.	Set INPUT SEL switch S3 to R.	Model 8100 indicates 150 ± 8 ohms
2.	Same as step 1.	Controls in any position.	Set INPUT SEL switch S3 to T.	Model 8100 indicates 5100 ± 255 ohms.
3.	Same as step 1.	INPUT SEL switch S3: T.	Remove one test probe from AUDIO OSC-GND binding post J1 and make firm contact with pin 3 of test cable connector P1.	Model 8100 indicates 5.1 ± 0.26 ohms.

d. Closeup.

(1) Disconnect the Model 8100 from the interphone test set.

(2) Close and secure the cover on the interphone test set.

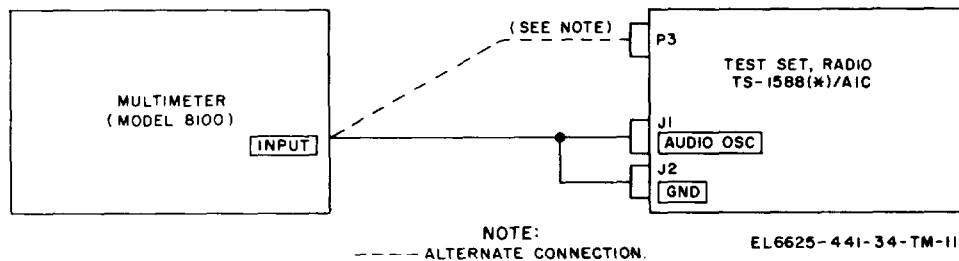

Figure 4-1. Test Set, Radio TS-1588 (*)/AIC resistance check connection diagram.

4-5. Electrical Tests

(fig. 4-2)

a. Test Equipment and Materials. John Fluke Multimeter Model 8100 (or equivalent) and 28-volt dc power source are required to perform and accomplish the electrical tests on the interphone test set. No special materials are required.

b. Preparation.

{1} Remove the cover from the interphone test set.

(2) Set POWER-OFF switch S7 to OFF.

(3) Insure that the 28-volt dc power supply is off.

(4) Connect the red insulated power supply cable clip to the + 28V DC (positive pole) terminal.

(5) Connect the black insulated power supply cable clip to the --28V DC (negative pole) terminal.

c. Procedure. The electrical tests chart shows the step-by-step procedures to be followed during performance of the interphone test set electrical tests.

step No.	Test equipment control settings	Equipment under test control settings	Test procedures	Performance standard
1.	None.	Controls in any position.	Set POWER-OFF switch S7 to POWER.	OPERATE lamp 11 lights.
2.	VDC: Depressed RANGE: 100	POWER-OFF switch S7; in POWER.	Observe Model 8100.	Model 8100 indicates 27.0 ± 0.5 Vdc.
3.	None.	Same as step 2.	Insert test cable connector P1 into SELF TEST RECEPTACLE J8.	a. SELF TEST lamp 12 lights. b. OPERATE lamp 11 goes out.
4.	None.	RECEIVER SEL switch S4: OFF; TRANSMITTER SEL switch S5: 1; INPUT SEL switch S3: R; Signal switch: METER.	Hold KEYING switch S1 to RADIO and then to INTER.	KEY ON lamp 13 lights when KEYING switch S1 is in RADIO and INTER positions, and goes out in midposition.
5.	None.	RECEIVER SEL switch S4: OFF; SIGNAL switch: METER; TRANSMITTER SEL switch S5: 2; INPUT SEL switch S3: R.	a. Hold KEYING switch S1 to RADIO and then to INTER for each setting of TRANSMITTER SEL switch S5. b. Repeat step a with TRANSMITTER SEL switch S5 in positions 3, 4, and ALTN.	a. Same as step 4. b. Same as step 4.
6.	None.	Test Set, Radio TS-1588/AIC TRANSMITTER SEL switch S5: 4. Test Set, Radio TS- 1588 A/AIC TRANSMITTER SEL switch S5: A L T N; other switches same as step 5.	Hold SIGNAL switch S6 to HD MIC and release.	KEY ON lamp 13 shall light when SIGNAL switch S6 is in HD MIC and go out when released.
7.	None.	Same as step 6 except OUTPUT SEL switch S2: 1.	Same as step 6.	Same as step 6.
8.	None.	OUTPUT SEL switch S2: T. Test Set, Radio TS-1588/AIC TRANSMITTER SEL switch S5: 3, 2, and 1. Test Set, Radio TS-1588A/AIC TRANSMITTER SEL switch S5, 4, 3, 2, end 1.	Same as step 6.	Same as step 6.
9.	None.	TRANSMITTER SEL switch S5: 1.	a. Rotate Test Set, Radio TS-1588/AIC RECEIVER SEL switch S4 from 1 through INTER. b. Rotate Test Set, Radio TS-1588A/AIC RECEIVER SEL switch S4 from 1 through EMER.	a. KEY ON lamp 13 shall light for each RECEIVER SEL switch S4 position. b. Same as a. above.
10.	None.	RECEIVER SEL switch S4: OFF. TRANSMITTER SEL switch S5 to 1. OUTPUT SEL switch S2 to R.	Rotate INPUT SEL switch S3 to I and then T.	KEY ON lamp 13 lights with INPUT SEL switch S3 in I and does not light in T.
11.	None.	Controls in any position.	Remove test cable connector P1 from SELF TEST RECEPTACLE J8,	SELF TEST lamp 12 goes out and OPERATE lamp 11 lights.

d. Closeup.

(1) Disconnect Model 8100 from the interphone test set.

(2) close and secure the cover on the interphone test set.

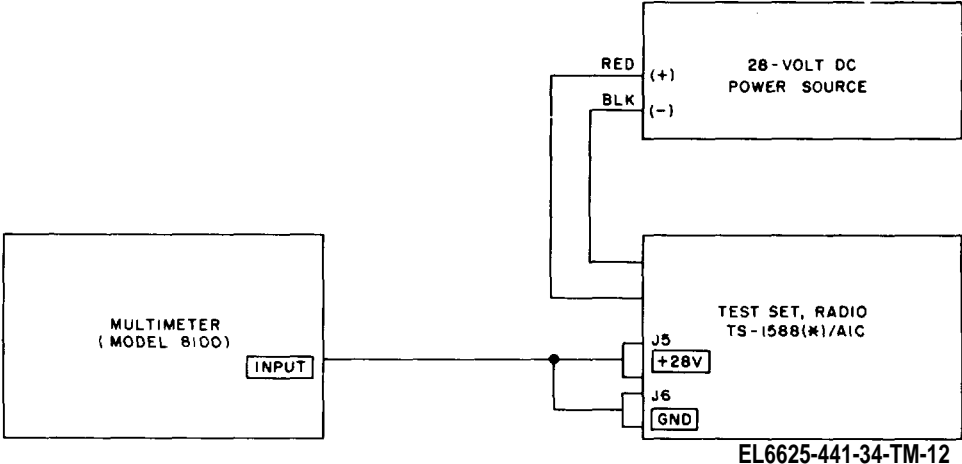

Figure 4-2. Test Set, Radio TS-1588(*)/AIC electrical test connection diagram.

APPENDIX A

REFERENCES

The following is a list of applicable references available to the direct support and general support maintenance repairman of Test Set, Radio TS-1588(*)/AIC.

DA Pamphlet 310-4	Index of Technical Manuals, Technical Bulletins, Supply Manuals (Types 7, 8, and 9), Supply Bulletins, and Lubrication Orders.
DA Pamphlet 310-7	US Army Equipment Index of Modification Work Orders.
TM 11-5126	Power Supplies PP-1104A/G and PH-1104BG.
TM 11-5831-201-20	Organizational Maintenance Manual: Control, Intercommunication Set C-1611D/AIC and Discriminator, Discrete Signal MD-736/A.
TM 11-5831-201-35	DS, GS, and Depot Maintenance Manual: Control, Intercommunication Set C- 1611 D/AIC and Discriminator, Discrete Signal MD-736/A.
TM 11-6625-366-15	Operator's, Organizational, DS, GS, and Depot Maintenance Manual: Multimeter TS-352B/U.
TM 11-6625-441-12	Operator's and Organizational Maintenance Manual: Test Set, Radio TS-1588/AIC and TS-1588A/AIC.
TM 11-6625-441-20P	Organizational Maintenance Repair Parts and Special Tools Lists: Test Sets TS-1588/AIC and TS-1588A/AIC (FSN 6625-895-6646 and FSN 6625-239-6010).
TM 11-6625-441-34P	Direct Support and General Support Maintenance Repair Parts and Special Tools Lists (Including Depot Maintenance Repair Parts and Special Tools) Test Set, Radio TS-1588/AIC (FSN 6625-895-6646); Test Set, Radio TS-1588A/AIC (FSN 6625-239-6016).
TM 38-750	The Army Maintenance Management System (TAMMS).

By Order of the Secretary of the Army:

Official:
VERNE L. BOWERS
*Major General, United States Army,
The Adjutant General.*

FRED C. WEYAND
*General, United States Army,
Chief of Staff.*

Distribution:

To be distributed in accordance with DA Form 12-36A, (qty rqr block No. 1161) Direct and General Support maintenance requirements for TS-1588 ()/AIC.

RECOMMENDED CHANGES TO EQUIPMENT TECHNICAL PUBLICATIONS



THEN...JOT DOWN THE
DOPE ABOUT IT ON THIS FORM.
CAREFULLY TEAR IT OUT, FOLD IT
AND DROP IT IN THE MAIL.

SOMETHING WRONG WITH PUBLICATION

FROM: (PRINT YOUR UNIT'S COMPLETE ADDRESS)

DATE SENT

PUBLICATION NUMBER

PUBLICATION DATE

PUBLICATION TITLE

BE EXACT PIN-POINT WHERE IT IS

PAGE
NO.

PARA-
GRAPH

FIGURE
NO.

TABLE
NO.

IN THIS SPACE, TELL WHAT IS WRONG
AND WHAT SHOULD BE DONE ABOUT IT.

TEAR ALONG PERFORATED LINE

PRINTED NAME, GRADE OR TITLE AND TELEPHONE NUMBER

SIGN HERE

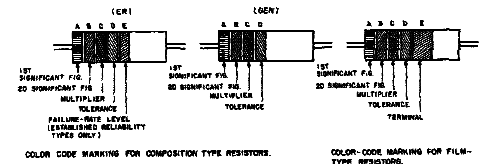

TABLE 1
COLOR CODE FOR COMPOSITION TYPE AND FILM TYPE RESISTORS.

BAND A		BAND B		BAND C		BAND D		BAND E	
COLOR	FIRST SIGNIFICANT FIGURE	COLOR	SECOND SIGNIFICANT FIGURE	COLOR	MULTIPLIER	COLOR	RESISTANCE TOLERANCE (PERCENT)	COLOR	FAILURE RATE LEVEL
BLACK	0	BLACK	0	BLACK	1	BROWN	±10	BROWN	N-10
BROWN	1	BROWN	1	BROWN	10	RED	±2	RED	1000
RED	2	RED	2	RED	100	ORANGE	±3	ORANGE	10000
ORANGE	3	ORANGE	3	ORANGE	1000	YELLOW	±4	YELLOW	100000
YELLOW	4	YELLOW	4	YELLOW	10000	SILVER	±10 (COM. TYPE ONLY)	WHITE	SOLD-DRABLE
GREEN	5	GREEN	5	BROWN	100,000	GOLD	±5		
BLUE	6	BLUE	6	BLUE	1,000,000	RED	±5 (NOT APPLICABLE TO COM. TYPE ONLY)		
PURPLE	7	PURPLE	7						
VIOLET	8	VIOLET	8	SILVER	0.1				
GRAY	9	GRAY	9	SILVER	0.01				
WHITE	9	WHITE	9	SOLD	0.1				

BAND A — THE FIRST SIGNIFICANT FIGURE OF THE RESISTANCE VALUE (BANDS A THRU D SHALL BE OF EQUAL WIDTH).

BAND B — THE SECOND SIGNIFICANT FIGURE OF THE RESISTANCE VALUE.

BAND C — THE MULTIPLIER (THE MULTIPLIER IS THE FACTOR BY WHICH THE TWO SIGNIFICANT FIGURES ARE MULTIPLIED TO YIELD THE NORMAL RESISTANCE VALUE.)

BAND D — THE RESISTANCE TOLERANCE.

BAND E — WHEN USED ON COMPOSITION RESISTORS, BAND E INDICATES ESTABLISHED RELIABILITY FAILURE RATE LEVEL (PERCENT FAILURE PER 1000 HOURS ON FILM RESISTORS, THIS BAND SHALL BE APPROXIMATELY 1/10 TIMES THE WIDTH OF OTHER BANDS AND INDICATES THE TERMINAL RESISTANCES IDENTIFIED BY NUMBERS AND LETTERS (THESE ARE NOT COLOR CODED).

SOME RESISTORS ARE IDENTIFIED BY THREE OR FOUR DIGIT ALPHA NUMERIC RESISTORS. THE LETTER R IS USED IN PLACE OF A DECIMAL POINT WHEN FRACTIONAL VALUES OF AN OHM ARE EXPRESSED. FOR EXAMPLE:
DR7 = 5.7 OHMS 1000 = 10.0 OHMS

FOR MIL-C-10000 TYPE RESISTORS COLOR CODES ARE NOT USED. IDENTIFICATION MARKING IS PROVIDED IN EACH OF THE APPLICABLE SPECIFICATIONS.

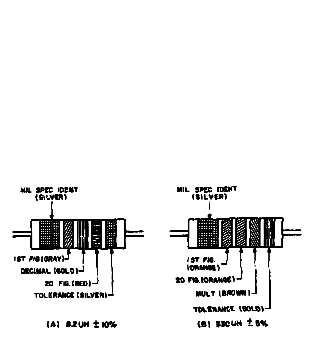
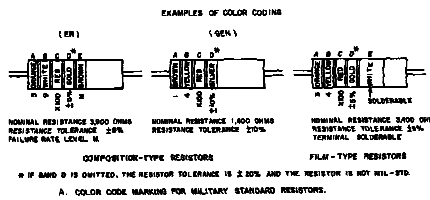

COLOR CODING FOR TUBULAR ENCAPSULATED INDUCTORS AT A, AN EXAMPLE OF THE CODING FOR AN 8.2MH OHM IS GIVEN. AT B, THE COLOR BANDS FOR 8.2MH INDUCTOR ARE ILLUSTRATED.

TABLE 2
COLOR CODING FOR TUBULAR ENCAPSULATED INDUCTORS

COLOR	SECOND SIGNIFICANT FIGURE	MULTIPLIER	INDUCTIVE TOLERANCE (PERCENT)
BLACK	0	1	±1
BROWN	1	10	±1
RED	2	100	±2
ORANGE	3	1,000	±3
YELLOW	4		
GREEN	5		
BLUE	6		
VIOLET	7		
GRAY	8		
WHITE	9		
SILVER		0.1	±10
GOLD		0.01	±5

MULTIPLIER IS THE FACTOR BY WHICH THE TWO COLOR FIGURES ARE MULTIPLIED TO OBTAIN THE INDUCTIVE VALUE OF THE COIL.

B. COLOR CODE MARKING FOR MILITARY STANDARD INDUCTORS.

CAPACITORS, FIXED, VARIOUS-DIELECTRICS, STYLES CM, CN, CY, AND CB.

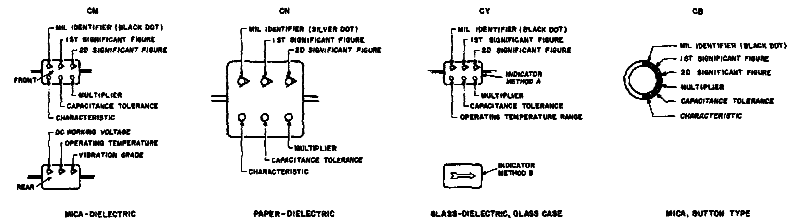

MICA-DIELECTRIC, PAPER-DIELECTRIC, GLASS-DIELECTRIC, GLASS CASE, MICA, BUTTON TYPE.

TABLE 3 — FOR USE WITH STYLES CM, CN, CY AND CB.

COLOR	MIL TO FILE	1ST FIG.	2ND FIG.	MULTIPLIER	CAPACITANCE TOLERANCE	CHARACTERISTIC	TEMP. RANGE	VIBRATION GRADE
BLACK	0	0	0	1	±10%	W	E	F
BROWN	1	1	10	100	±20%	W	E	F
RED	2	2	100	1000	±20%	W	E	F
ORANGE	3	3	1,000	10,000	±20%	W	E	F
YELLOW	4	4	10,000			W	E	F
GREEN	5	5				W	E	F
BLUE	6	6				W	E	F
VIOLET	7	7				W	E	F
GRAY	8	8				W	E	F
WHITE	9	9				W	E	F
SOLD				0.1	±10%	W	E	F
SILVER	CM			0.01	±10%	W	E	F

TABLE 4 — TEMPERATURE COMPENSATING, STYLE CC.

COLOR	TEMPERATURE COEFFICIENT	1ST FIG.	2ND FIG.	MULTIPLIER	CAPACITANCE TOLERANCE	CHARACTERISTIC
BLACK	0	0	0	1	±10%	W
BROWN	-30	1	10	100	±1%	W
RED	-30	2	2	100	±2%	W
ORANGE	-30	3	3	1,000	±2%	W
YELLOW	-30	4	4			W
GREEN	-30	5	5			W
BLUE	-40	6	6			W
VIOLET	-40	7	7			W
GRAY	-40	8	8			W
WHITE	-40	9	9			W
SOLD				0.1	±10%	W
SILVER				0.01	±10%	W

- THE MULTIPLIER IS THE NUMBER BY WHICH THE TWO SIGNIFICANT (1ST) FIGURES ARE MULTIPLIED TO OBTAIN THE CAPACITANCE IN UUF.
- LETTERS INDICATE THE CHARACTERISTICS DESIGNATED IN APPLICABLE SPECIFICATIONS: MIL-C-1, MIL-C-2, MIL-C-3, MIL-C-4, MIL-C-5, MIL-C-6, MIL-C-7, MIL-C-8, MIL-C-9, MIL-C-10, MIL-C-11, MIL-C-12, MIL-C-13, MIL-C-14, MIL-C-15, MIL-C-16, MIL-C-17, MIL-C-18, MIL-C-19, MIL-C-20, MIL-C-21, MIL-C-22, MIL-C-23, MIL-C-24, MIL-C-25, MIL-C-26, MIL-C-27, MIL-C-28, MIL-C-29, MIL-C-30, MIL-C-31, MIL-C-32, MIL-C-33, MIL-C-34, MIL-C-35, MIL-C-36, MIL-C-37, MIL-C-38, MIL-C-39, MIL-C-40, MIL-C-41, MIL-C-42, MIL-C-43, MIL-C-44, MIL-C-45, MIL-C-46, MIL-C-47, MIL-C-48, MIL-C-49, MIL-C-50, MIL-C-51, MIL-C-52, MIL-C-53, MIL-C-54, MIL-C-55, MIL-C-56, MIL-C-57, MIL-C-58, MIL-C-59, MIL-C-60, MIL-C-61, MIL-C-62, MIL-C-63, MIL-C-64, MIL-C-65, MIL-C-66, MIL-C-67, MIL-C-68, MIL-C-69, MIL-C-70, MIL-C-71, MIL-C-72, MIL-C-73, MIL-C-74, MIL-C-75, MIL-C-76, MIL-C-77, MIL-C-78, MIL-C-79, MIL-C-80, MIL-C-81, MIL-C-82, MIL-C-83, MIL-C-84, MIL-C-85, MIL-C-86, MIL-C-87, MIL-C-88, MIL-C-89, MIL-C-90, MIL-C-91, MIL-C-92, MIL-C-93, MIL-C-94, MIL-C-95, MIL-C-96, MIL-C-97, MIL-C-98, MIL-C-99, MIL-C-100.
- LETTERS INDICATE THE TEMPERATURE RANGE AND VOLTAGE-TEMPERATURE LIMITS DESIGNATED IN MIL-C-10000.
- TEMPERATURE COEFFICIENT IN PARTS PER HELLON PER DEGREE CENTIGRADE.
- OPTIONAL CODES WHERE METALLIC ELEMENTS ARE UNDESIRABLE.

C. COLOR CODE MARKING FOR MILITARY STANDARD CAPACITORS.

Figure FO-1. Color code marking for MIL-STD resistors, inductors, and capacitors.

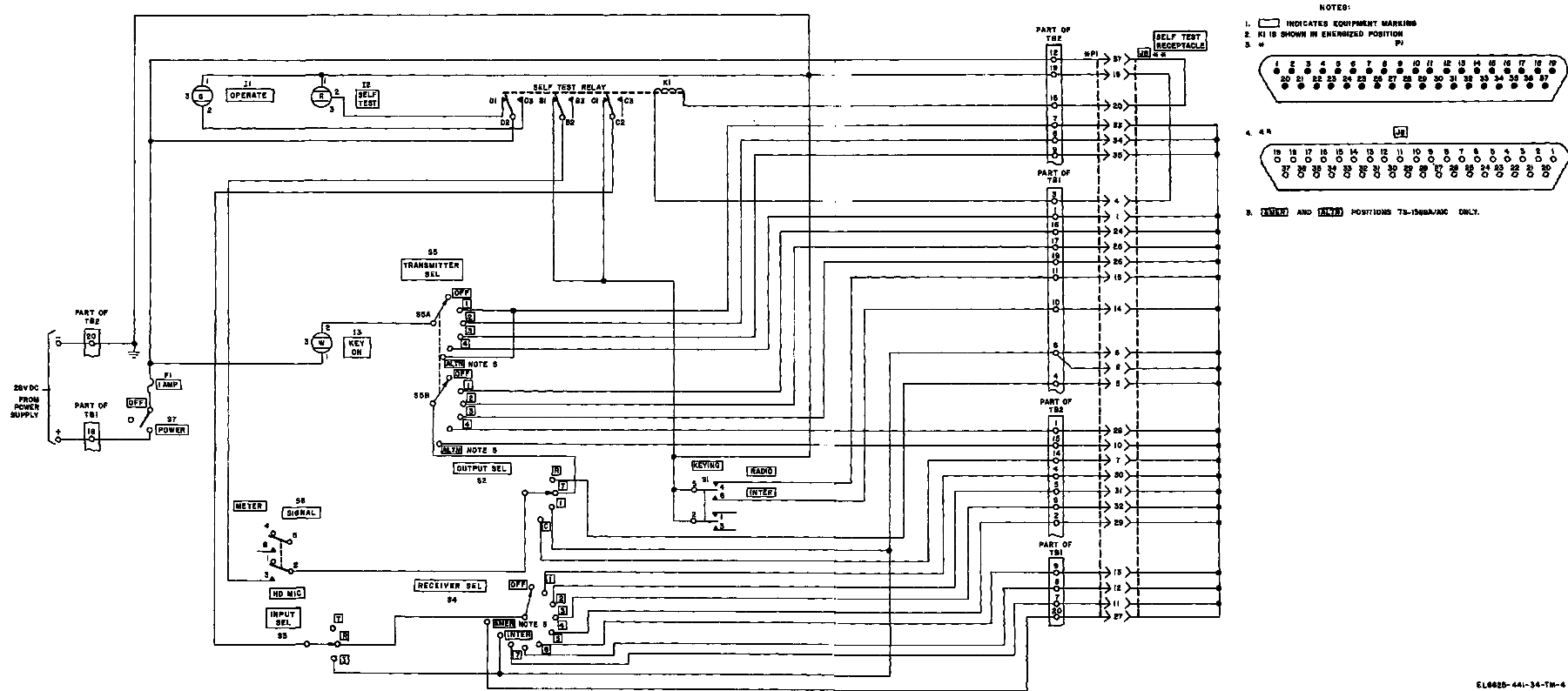

Figure FO-2. Test, Set, Radio TS-1588(*)/AIC self-test circuits, simplified schematic diagram.

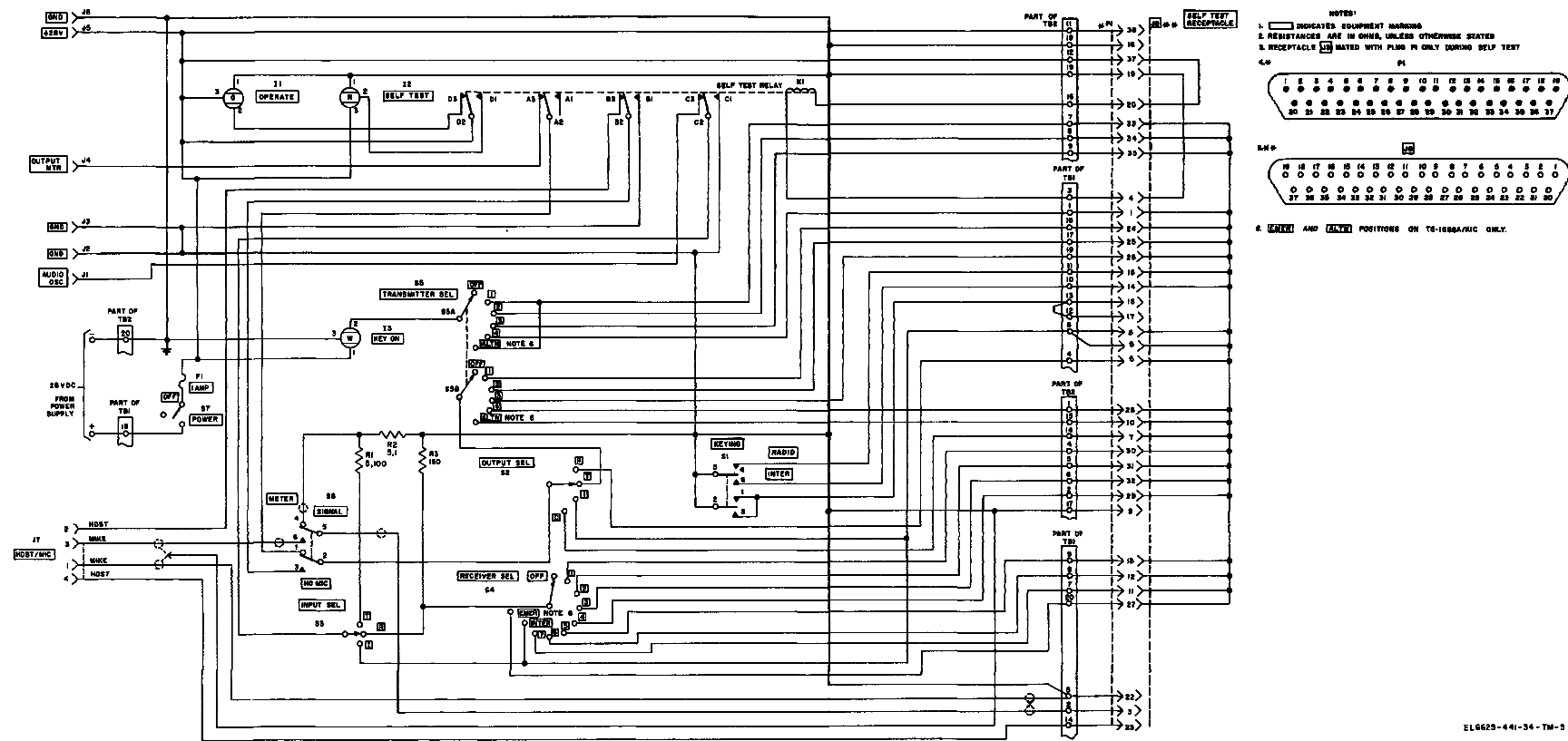
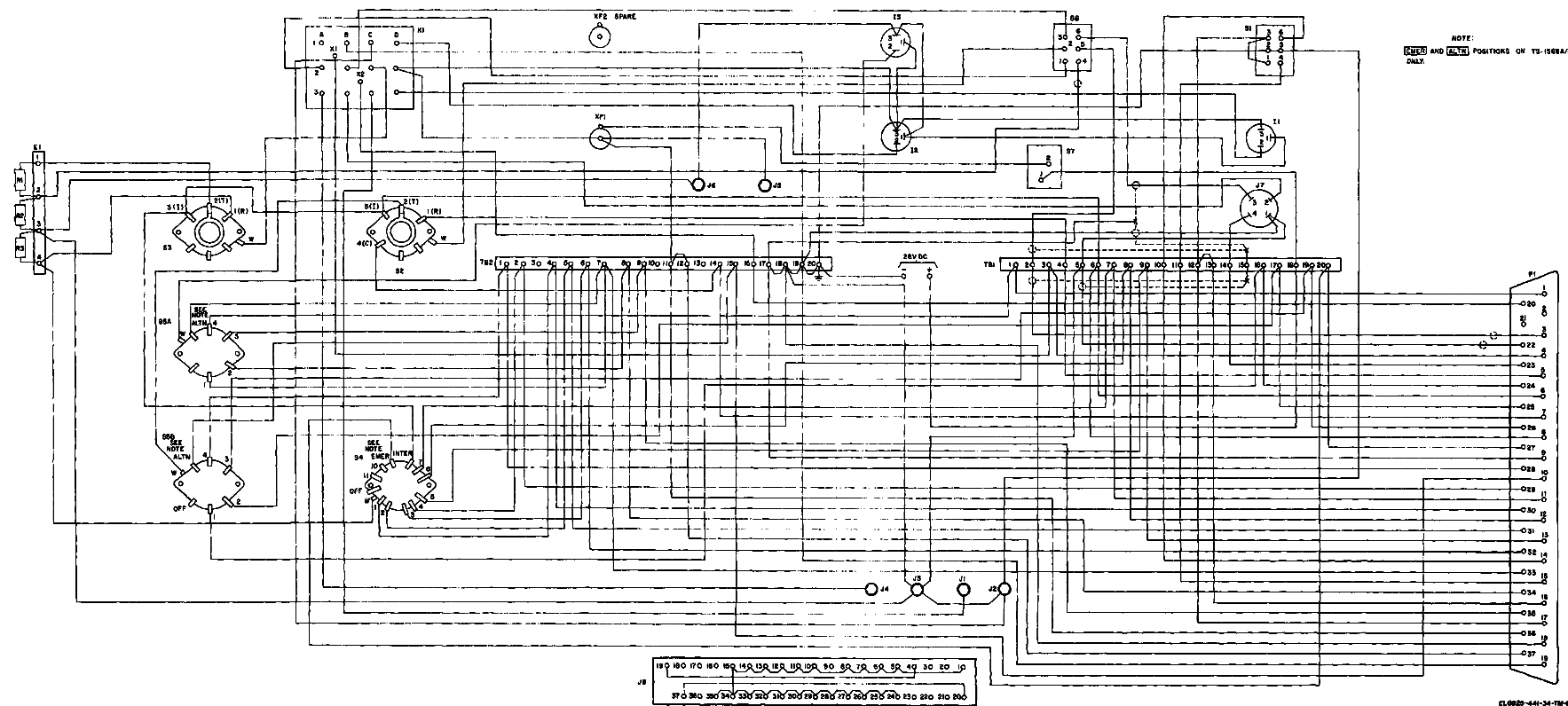

Figure FO-3. Test Set, Radio TS-1588(*)/AIC schematic diagram.



CL 6625-441-34-10-6

Figure FO-4. Test Set, Radio TS-1588(*)/AIC wiring diagram.

